

Stratos[®] HSSD[®]

HIGH SENSITIVITY ASPIRATING SMOKE DETECTOR

Minimum Display



Key Features

- Economy version Stratos-HSSD Standard detector in rugged sheet steel enclosure.
- Display offers indication of alarm, fault and normal operation.
- Programmable by RS 485 serial connection or Command Module.
- High sensitivity provided by laser based forward light scatter for reliable early warning.
- Unique ClassiFire[®] Perceptive Artificial Intelligence system that dynamically adjusts the detector's operating parameters, allowing for day to day changes in the protected environment and system contamination.
- Unwanted alarms from dust are avoided using patented Dual Technology LDD 3D[®] Laser Dust Discrimination and elimination system.
- 4 sampling pipes, up to 250m maximum total length.
- RS485 communications built in as standard for networking and remote communications.
- LPCB approved for up to 100 sampling holes.

Description

Stratos-HSSD has unmatched sensitivity potential, providing the very earliest warning of incipient fire with minimum rate of nuisance alarms.

ClassiFire Perceptive Artificial Intelligence ensures that the detector operates at optimum sensitivity for the protected environment, without the need for complex setup. This means the detector will configure itself to provide high sensitivity in a computer room or reduced sensitivity in a smoky area.

Volt-free Fire and Fault relay outputs are available for remote monitoring by local fire detection or BMS systems. Each detector is provided with 3 pairs of remote control input terminals. The inputs may be configured for number of functions, see technical documentation for full details.

Applications & Acceptance

Stratos detectors have been successfully applied in tens of thousands of applications worldwide, ranging from Clean Rooms to Casinos.

Options Available

- APIC[™] Addressable Protocol Interface Cards available for most industry signalling protocols.
- Command Module available for central monitoring and display.
- SenseNet computerised remote monitoring compatible - up to 127 detectors per loop.
- Remote Display units available.
- A lower cost Minimum Display option is available.
- Suitable for Stratos-MatrixScan, a patented software system which provides virtual addressable location detection - e.g. 10 physical detectors would provide up to 45 unique addressable locations.

Approvals

- Approved/listed by most major international fire protection certification agencies. (contact AirSense Technology for latest details).

Dimensions Stratos-HSSD Mounting plate

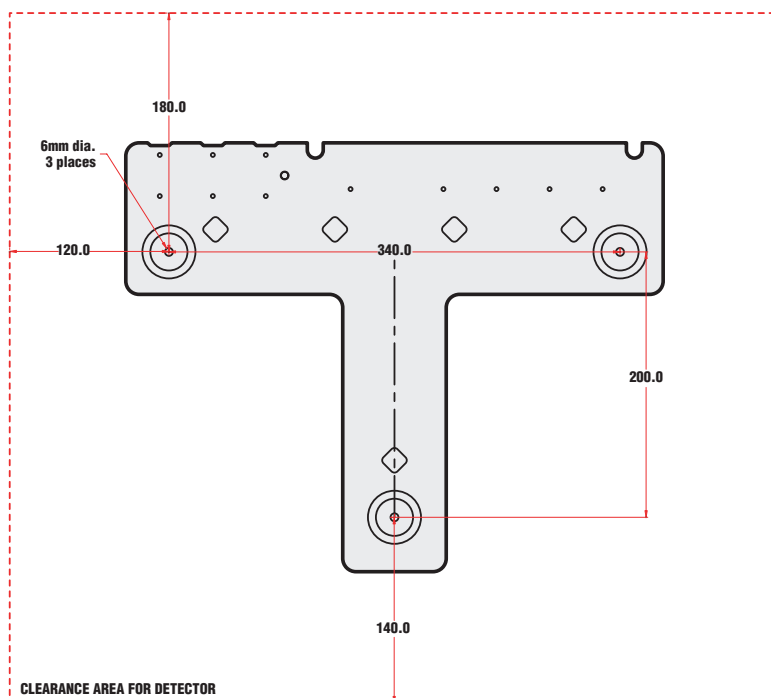

SPECIFICATIONS Stratos-HSSD Minimum Display

Supply Voltage	21.6V - 26.4V DC
Current consumption	450mA @ 24V DC at fan speed 8
Size	427W x 372H x 95D
Weight	5.2kg
Operating temperature range	-10 to +38°C (UL268) -10 to + 60°C (CEA4022)
Operating humidity range	0 - 90% non-condensing
Measurement range (%Obs/m)	0.0015% to 25%
Detection principle	Laser light scattering mass detection and particle evaluation
Particle sensitivity range	0.003µ to 10µ
Dust discrimination principle	3D ³ Laser Dust Discrimination (LDD)
Recommended max. single sampling pipe length	100m
Sampling pipe diameter	3/4" nominal bore (27mm O/D)

Total sampling pipe maximum	250m @ 80 sampling holes - 200m @ 100 sampling holes
Alarm levels	4 (Aux, Pre-alarm, Fire 1 and Fire 2)
Laser chamber service intervals	Greater than 10 years (dependent on environment)
Laser lifetime (MTTF)	Greater than 1000 years
Programming	Front panel, Command Module or PC via RS232/RS485
Network data bus	RS485
Maximum data bus length between detectors	1.2 km
IP rating	IP50
Sampling pipe inlets	4 on top, 4 at rear
Exhaust air pipe outlets	1 on top, 1 at rear

ORDERING INFORMATION

Part No.	Description
30710	Minimum Display Detector
30699	Replacement Dust Separator
30220	Setup and Servicing Software (free of charge)
30419	Serial PC Lead
30821	PS25 Power Supply

APPLICATIONS

- Data storage units
- Air duct protection
- Prison cells
- Heritage property protection
- Plant rooms
- Critical equipment
- Air conditioning units
- Anti-smoking enforcement
- Equipment racks
- Motor rooms
- Computer rooms



AirSense Technology Limited
 1 Caxton Place • Caxton Way • Stevenage • Herts • SG1 2UG • UK
 Tel: +44(0)1438 751296 • Fax: +44(0)1438 729137
 e-mail: sales@airsense.co.uk • www.airsensetechnology.com

AirSense Technology Limited (Hong Kong)
 1801 Wing On Central Building • 26 Des Voeux Road Central • Central Hong Kong
 Tel: (852) 2961 4206 • Fax: (852) 3007 4737
 e-mail: kevin.hui@airsense.co.uk



Quality system cert. no. 404
 Assessed to ISO 9001:2000